

# Fokker Dr.I

eduard

## GERMAN WWI FIGHTER

### 1/48 SCALE PLASTIC KIT

ProfiPACK  
edition

# #8162



## INTRO

At the time, Fokker had been preparing a fighter biplane for the Austro-Hungarian air force in the form of the V.4. In response to the Idflieg request, he simply added a third wing to the design. The Dr.I prototypes lacked interplane struts, but these were added in later machines to ensure synchronized wing reactions to forces during flight. Trials were initiated in June 1917, and showed enough promise to order a first batch of 20 series aircraft.

Two prototypes, only slightly differing from subsequent series built Dr.I machines and dubbed Fokker F.I, were tested under operational conditions in August, with production of the Dr.I then starting in October. After two fatal crashes caused by the failure of the top wing, all aircraft were returned to the factory for rework. Re-equipping units with the type occurred midway through December. They equipped elite fighter units, where they were flown by experienced aces. The aircraft was very maneuverable, but by the beginning of 1918, speed was not on par with British types being introduced into service, and the Dr.I aged quickly. As a result, the type was gradually replaced by the Fokker D.VII, but even so, several pilots kept this mount until the end of the war.

Despite a small production run of 230 units, the Dr. I became a legend and is synonymous with German fighter aircraft.

## ÚVODEM

Když se počátkem roku 1917 objevil na západní frontě britský Sopwith Triplane, předčil stoupavostí a obratností německé Albatrosy i Pfalzy. Inspektorát letectva (Idflieg) proto požadoval po výrobcích letadel podobný typ. Fokker tehdy připravoval pro rakousko-uherské letectvo stíhací dvouplošník V.4. Po výzvě Idfliegu jednoduše přidal k tomuto stroji třetí křídlo. Nový letoun neměl žádné mezikřídelní vzpěry, ale ty byly později přidány, aby zajistily souhlasné kroucení křídel. Zkoušky proběhly v červnu 1917 a byly natolik úspěšné, že již v červenci bylo objednáno prvních 20 sériových strojů.

Dva prototypy, mírně odlišné od pozdějších sériových Dr. I, označené Fokker F.I, byly od srpna zkoušeny v bojových podmínkách, dodávky Dr.I pak začaly v říjnu. Avšak poté, co došlo ke dvěma smrtelným nehodám po zhroucení konstrukce horního křídla, byly všechny stroje vráceny do továrny k přepracování. Dodávky byly obnoveny teprve v polovině prosince. Byly jimi vyzbrojovány elitní stíhací jednotky, kde s nimi létala zkušená stíhací esa. Stroj byl velmi obratný, ale počátkem roku 1918 již ve větších výškách nestačil rychlostí britským letounům a rychle zastarával. Průběžně byly Dr.I nahrazovány novými Fokkery D.VII, přesto si několik pilotů své trojplošníky ponechalo až do konce války.

Přes malý počet 320 vyrobených strojů se Dr. I stal legendou a synonymem německého stíhacího letadla.

ATTENTION



UPOZORNĚNÍ



ACHTUNG



ATTENTION



注意



Carefully read instruction sheet before assembling. When you use glue or paint, do not use near open flame and use in well ventilated room. Keep out of reach of small children. Children must not be allowed to suck any part, or pull vinyl bag over the head.



Před započítím stavby si pečlivě prostudujte stavební návod. Při používání barev a lepidel pracujte v dobře větrané místnosti. Lepidla ani barvy nepoužívejte v blízkosti otevřeného ohně. Model není určen malým dětem, mohlo by dojít k požití drobných dílů.

INSTRUCTION SIGNS



INSTR. SYMBOLY



INSTRUKTION SINNBILDEN



SYMBLES



記号の説明

OPTIONAL  
VOLBABEND  
OHNOUTOPEN HOLE  
VYVRTAT OTVORSYMETRICAL ASSEMBLY  
SYMETRICKÁ MONTÁŽNOTCH  
ZÁŘEZREMOVE  
ODRÍZNOUTAPPLY EDUARD MASK AND PAINT  
POUŽIT EDUARD'S MASK NABARVIT

PARTS



DÍLY



TEILE



PIÈCES



部品

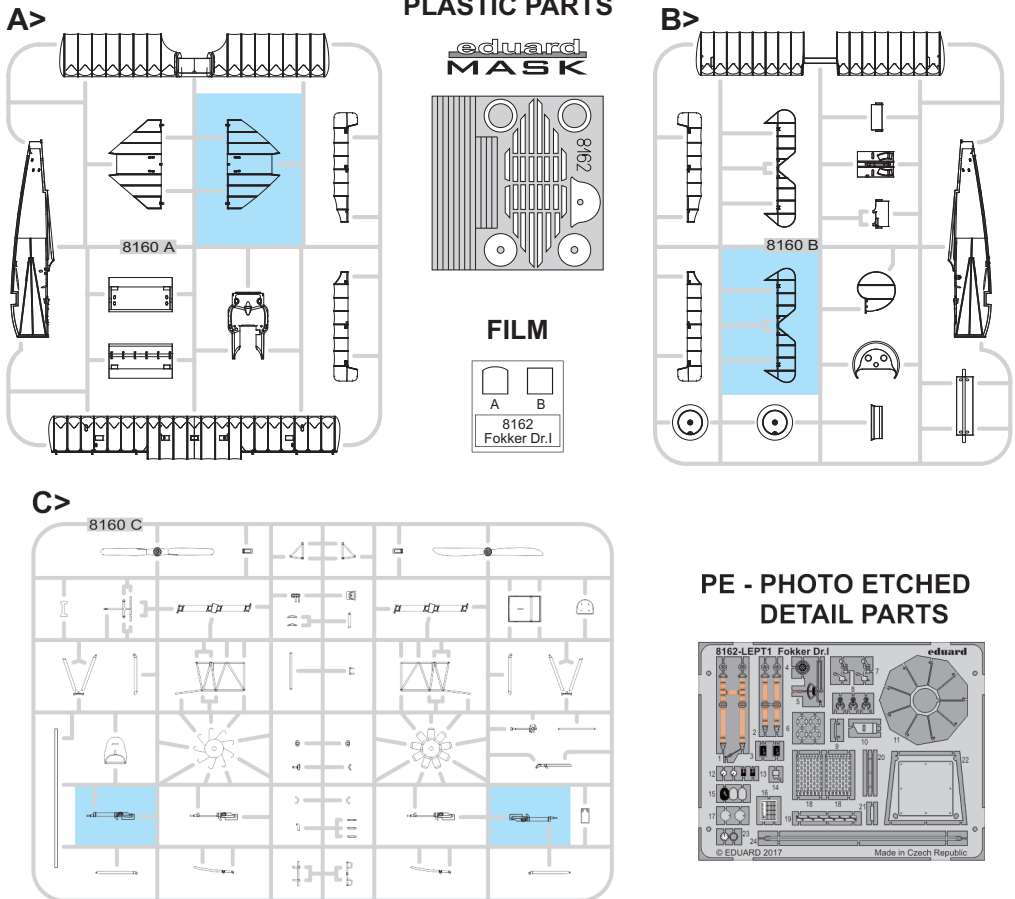

-Parts not for use. -Teile werden nicht verwendet. -Pièces à ne pas utiliser. -Tyto díly nepoužívejte při stavbě. - 使用しない部品

COLOURS



BARVY



FARBEN



PEINTURE



色

GSI Creos (GUNZE)		
AQUEOUS	Mr.COLOR	
<a href="#">H13</a>	<a href="#">C3</a>	RED
<a href="#">H11</a>	<a href="#">C62</a>	WHITE
<a href="#">H12</a>	<a href="#">C33</a>	BLACK
<a href="#">H10</a>	<a href="#">C28</a>	STEEL
<a href="#">H27</a>	<a href="#">C44</a>	TAN
<a href="#">H37</a>	<a href="#">C43</a>	WOOD BROWN
<a href="#">H67</a>	<a href="#">C41</a>	RED BROWN

AQUEOUS	Mr.COLOR	
<a href="#">H51</a>	<a href="#">C11</a>	LIGHT GULL GRAY
<a href="#">H52</a>	<a href="#">C12</a>	OLIVE DRAB
<a href="#">H70</a>	<a href="#">C60</a>	GRAY
<a href="#">H73</a>	<a href="#">C12</a>	OLIVE DRAB
<a href="#">H55</a>	<a href="#">C45</a>	SAIL COLOR
<a href="#">H43</a>	<a href="#">C13</a>	YELLOW
<a href="#">H74</a>	<a href="#">C74</a>	LIGHT BLUE

Mr.METAL COLOR	
<a href="#">MC215</a>	DARK IRON
<a href="#">MC216</a>	ALUMINIUM
<a href="#">MC219</a>	BRASS

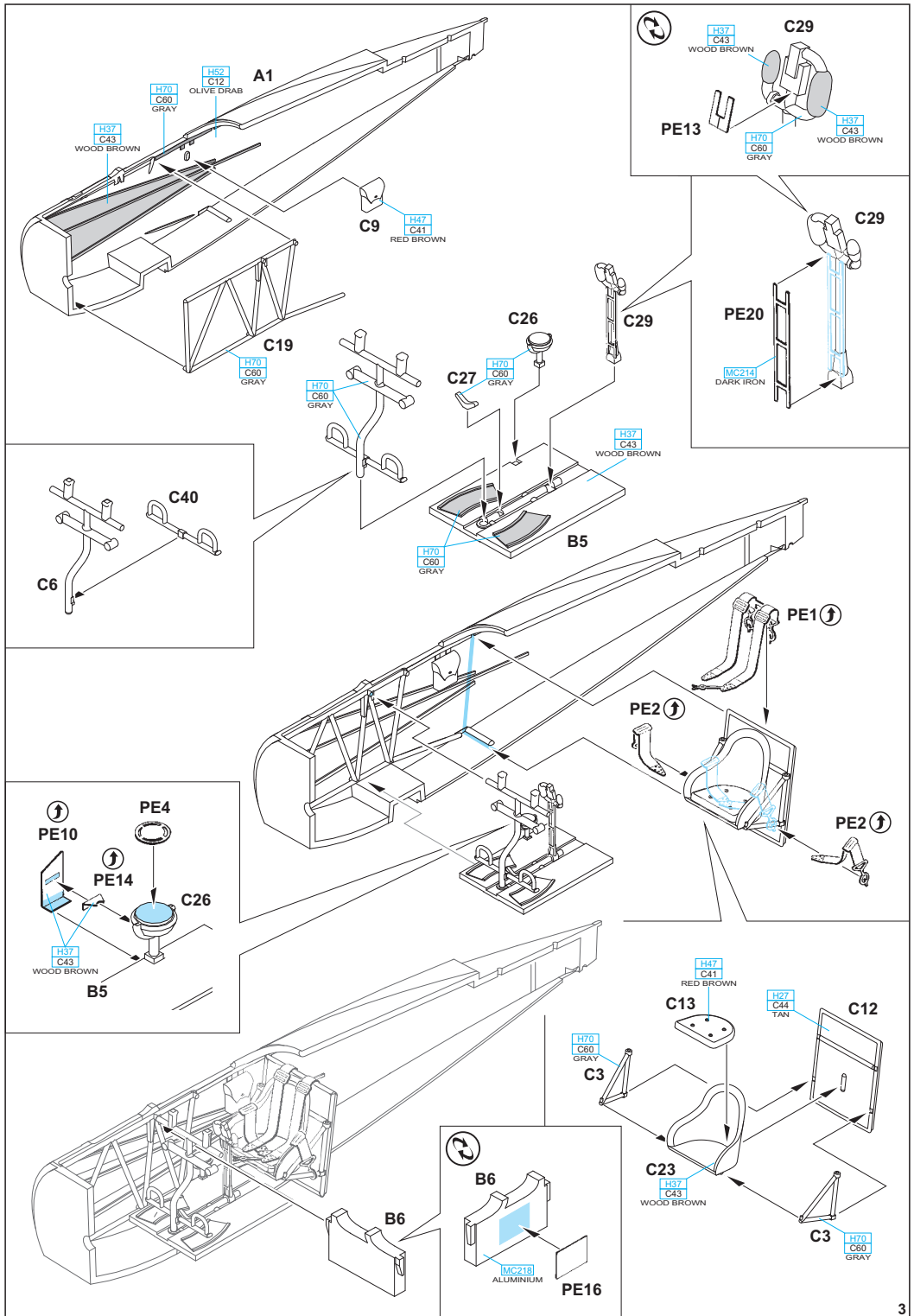

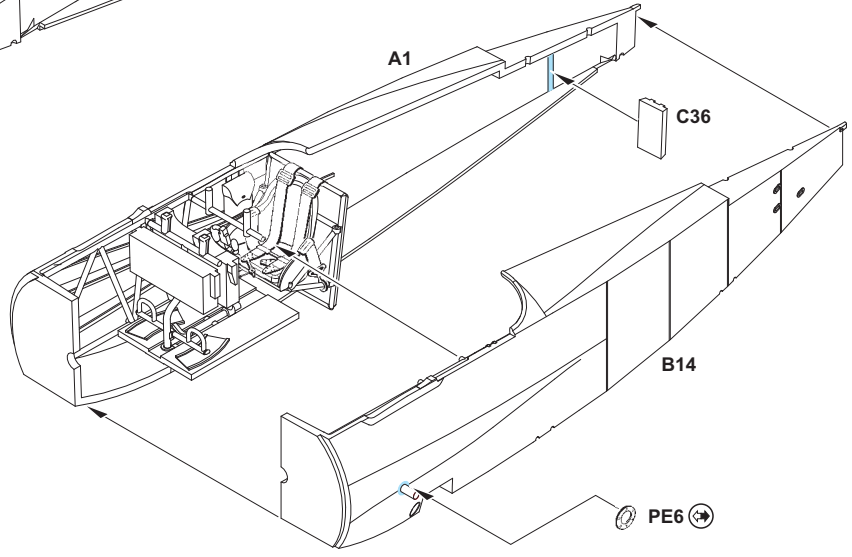
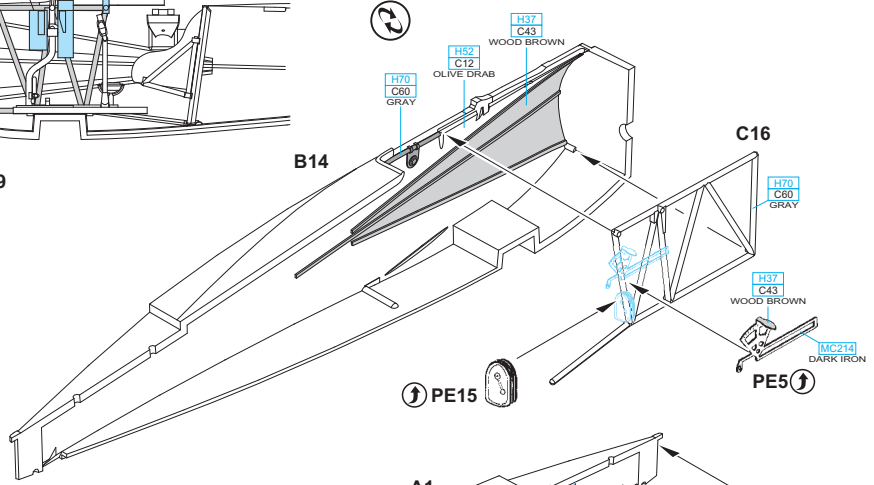
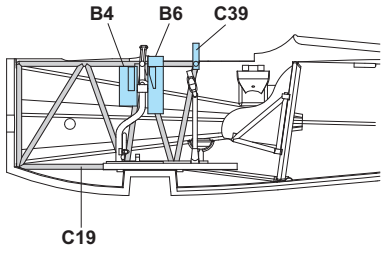
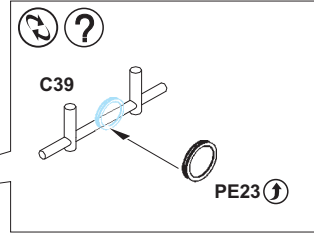
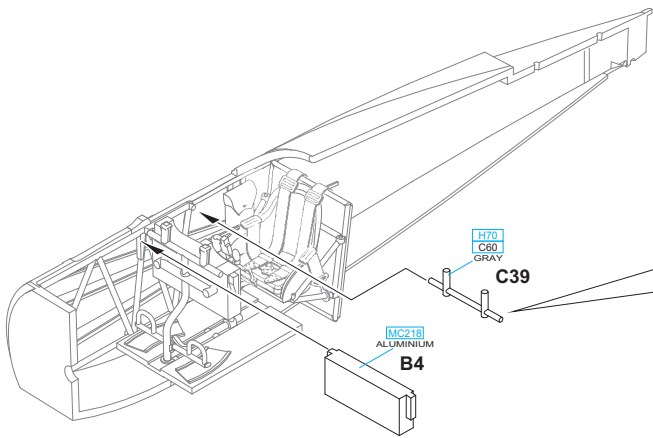



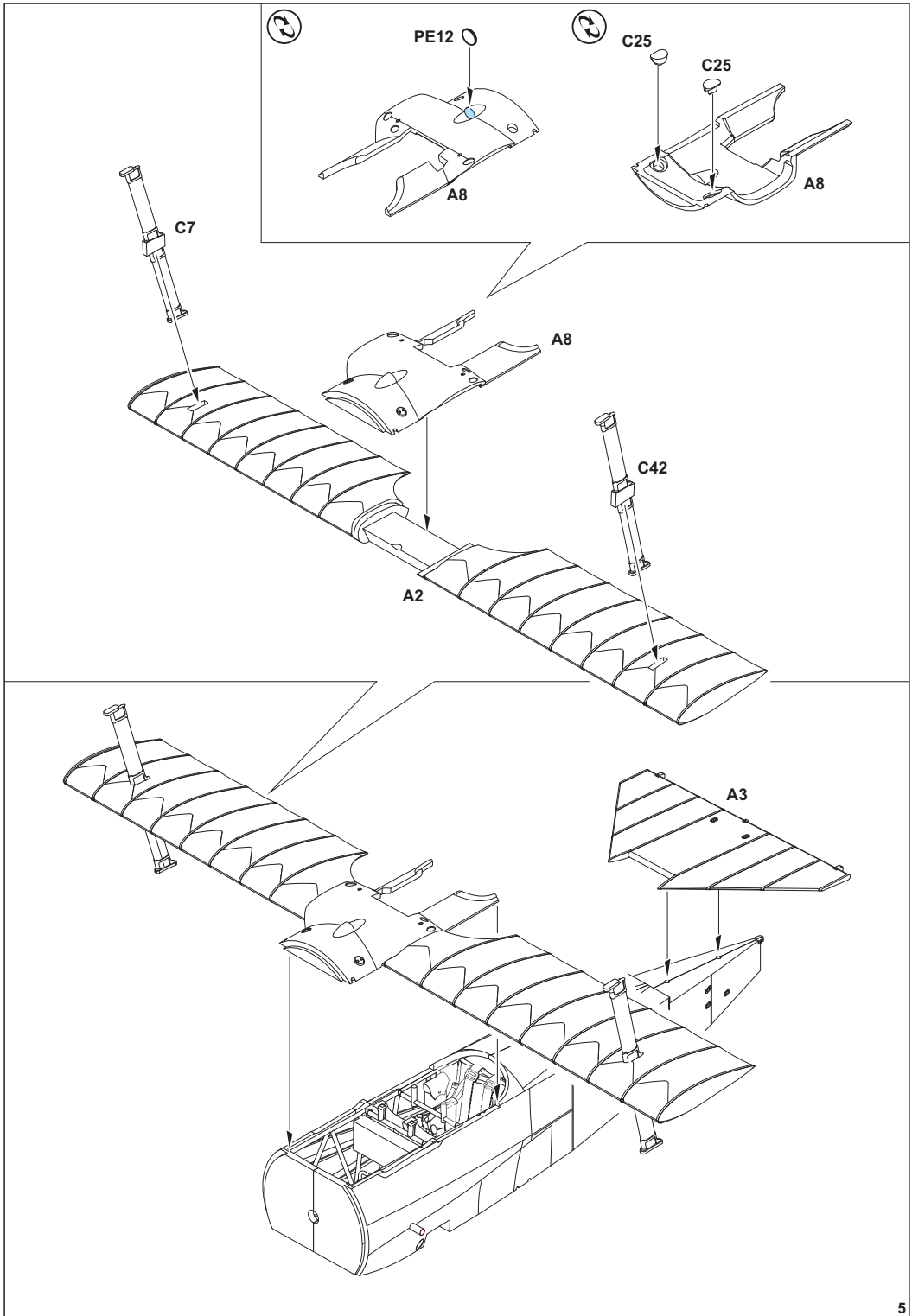

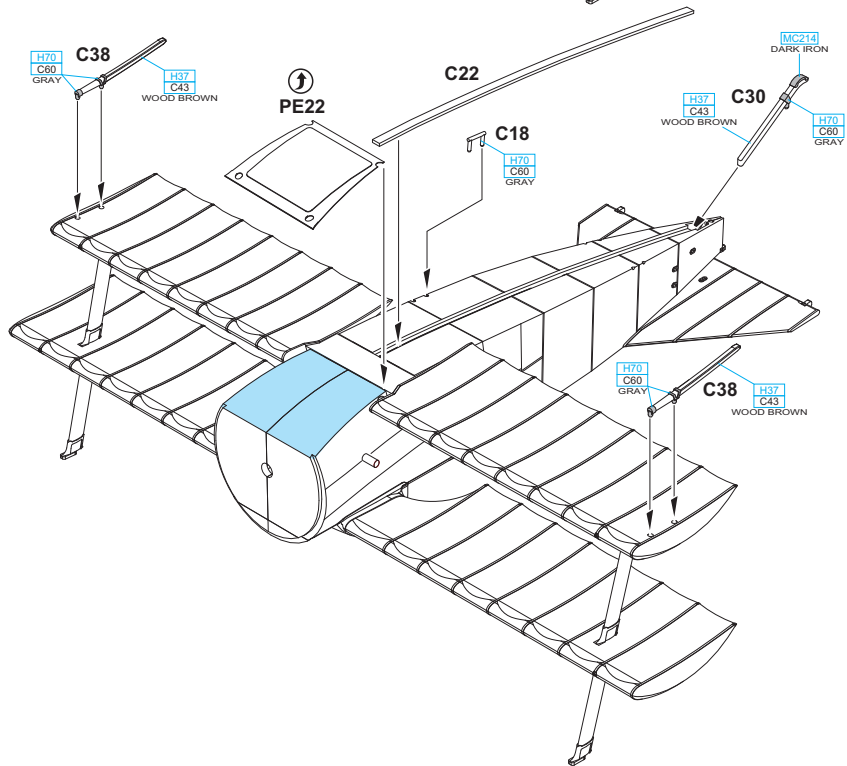
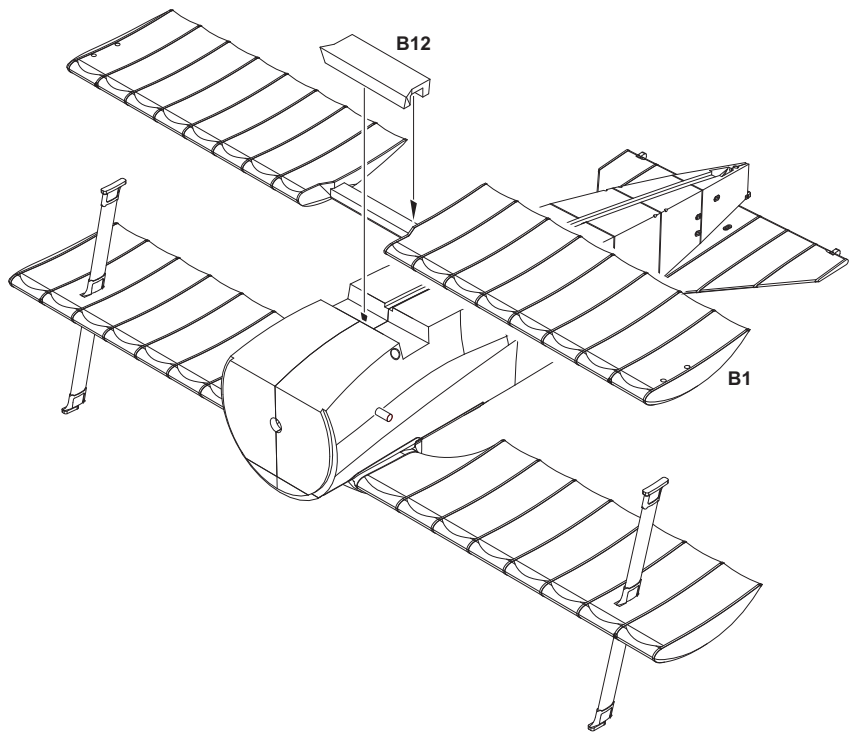

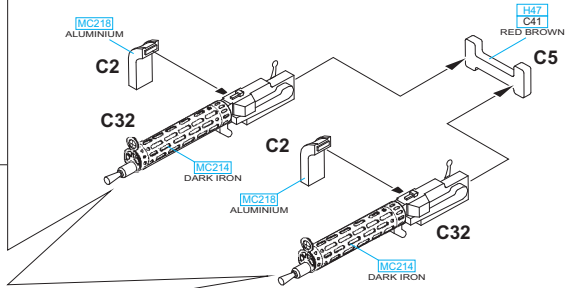
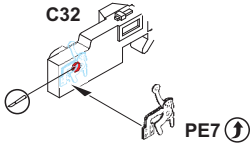
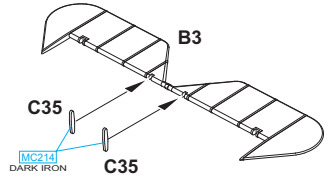
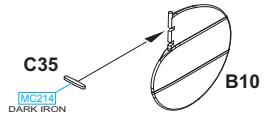
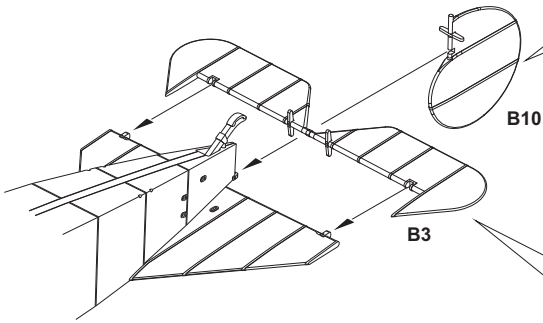

2 pcs.

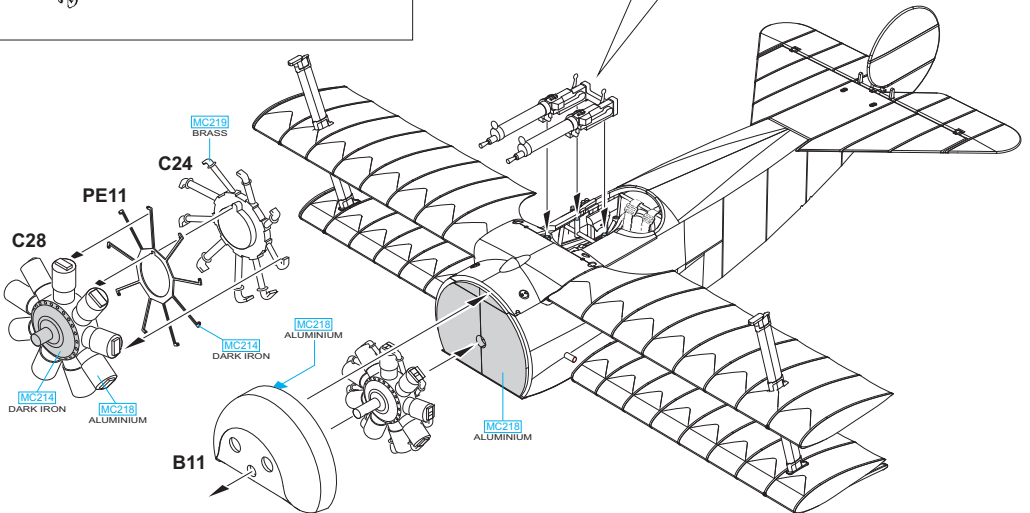
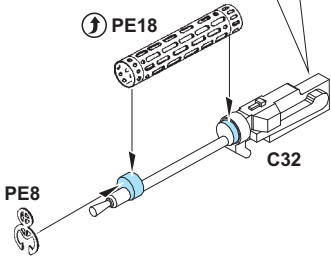

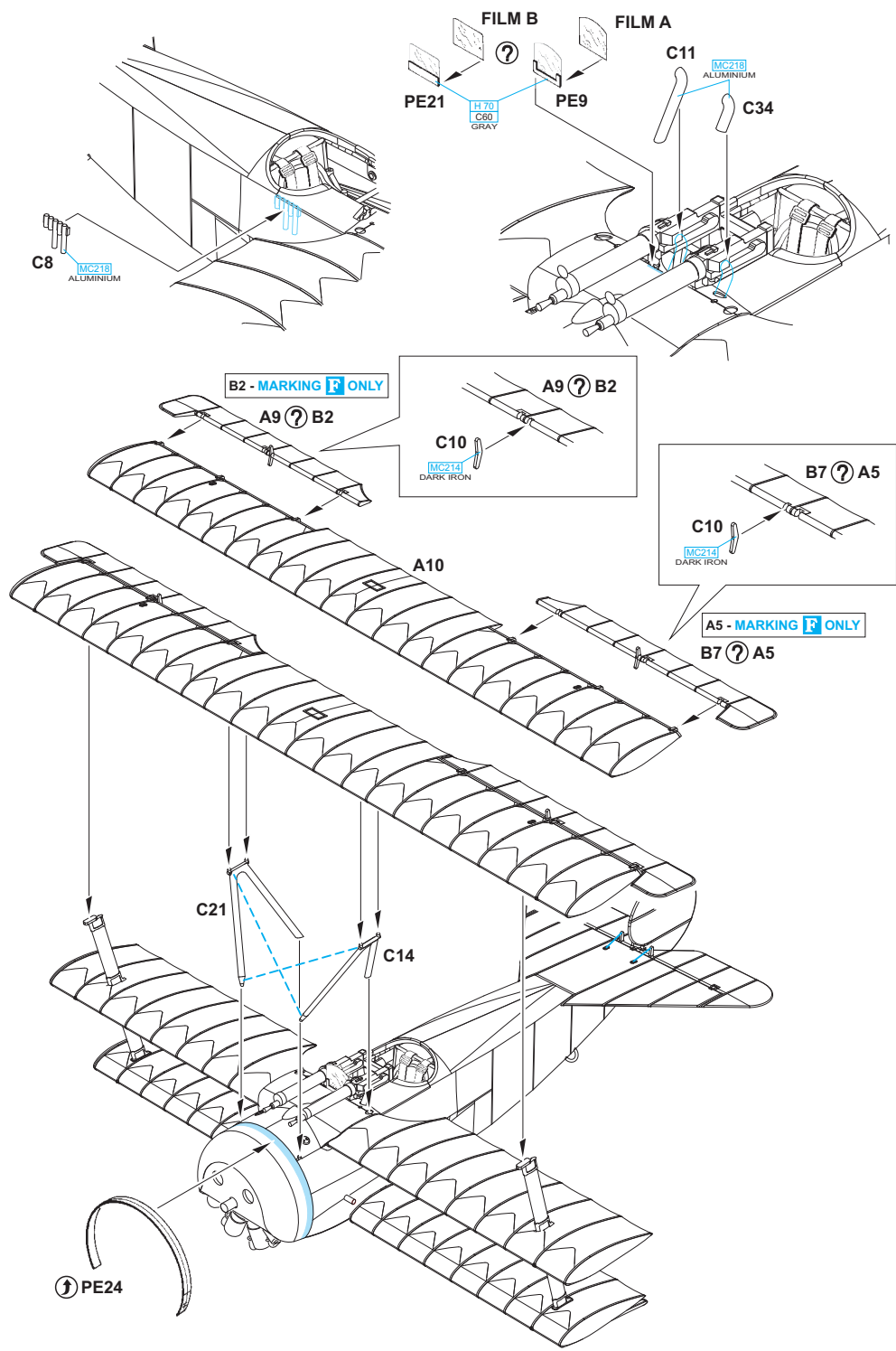

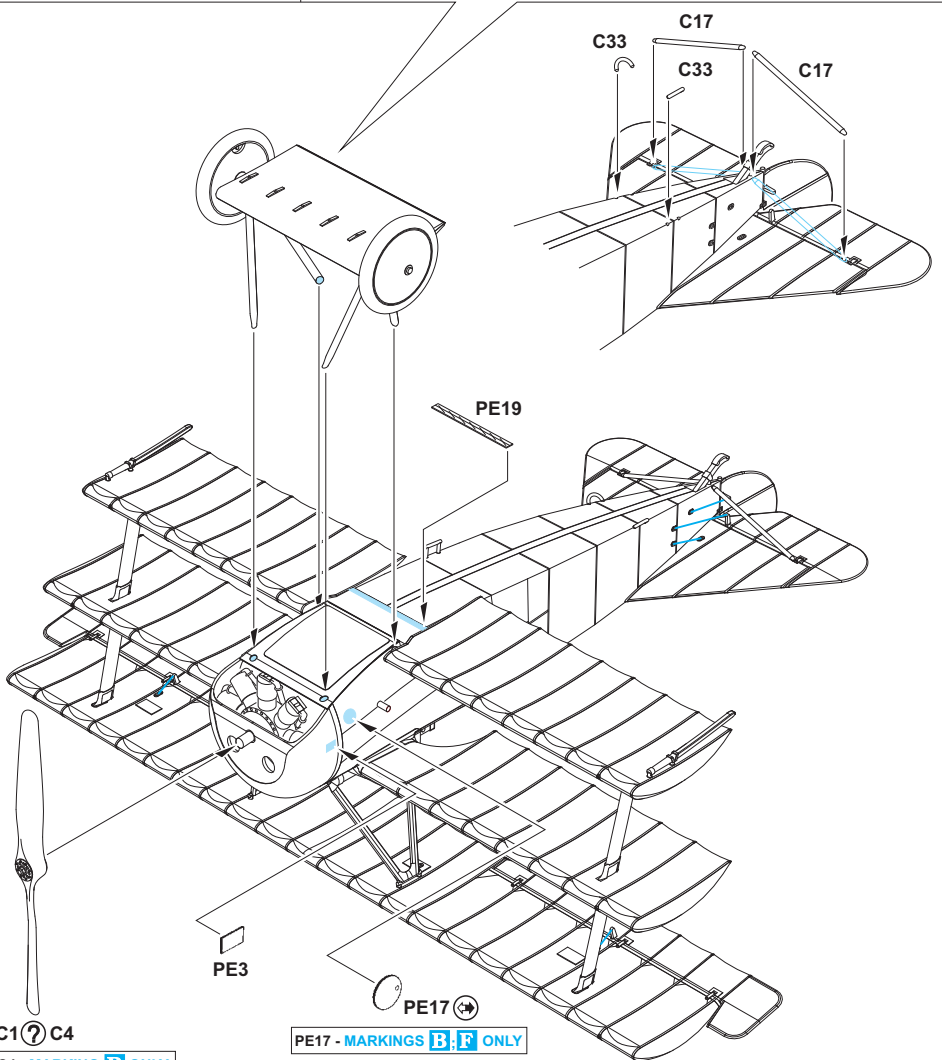
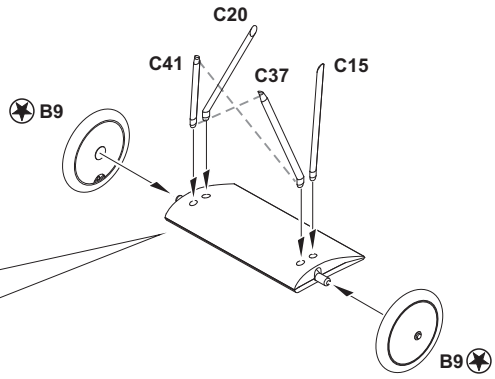
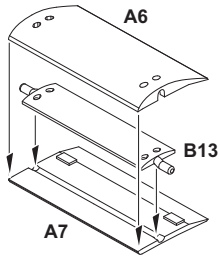

C1 ? C4

C4 - MARKING **B** ONLY

PE17 - MARKINGS **B, F** ONLY

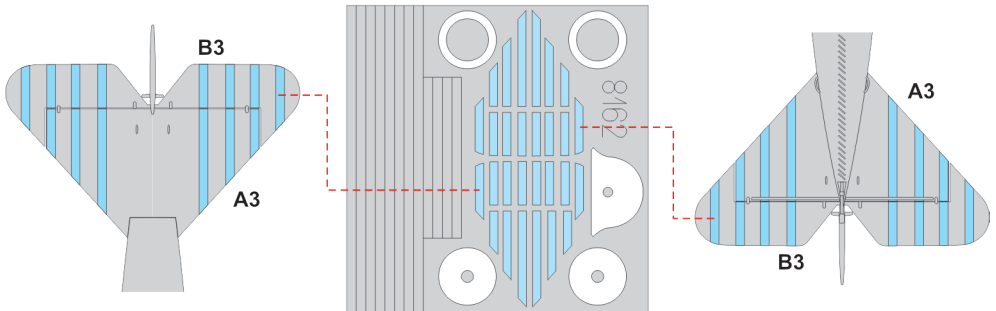
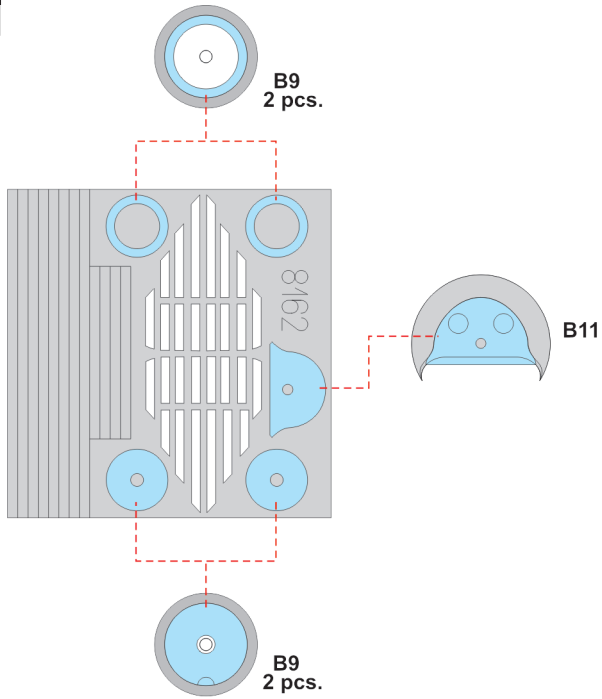

# A 425/17 flown by Rittmeister M. Freiherr von Richthofen, CO of JG 1, Cappy, France, April 1918

On April 21st, 1918, with this aircraft, Manfred von Richthofen attacked a Camel flown by Lt. May of No.209 Squadron, RAF. Captain Baker came to the latter's aid, and at the same time, several ground infantrymen fired on the red triplane. Who fired the fatal shot that struck the CO of JG 1 will probably never be discovered beyond the shadow of a doubt. In any case, on April 21th, 1918 at 11.50h, the final page in the life of Manfred von Richthofen had been written.

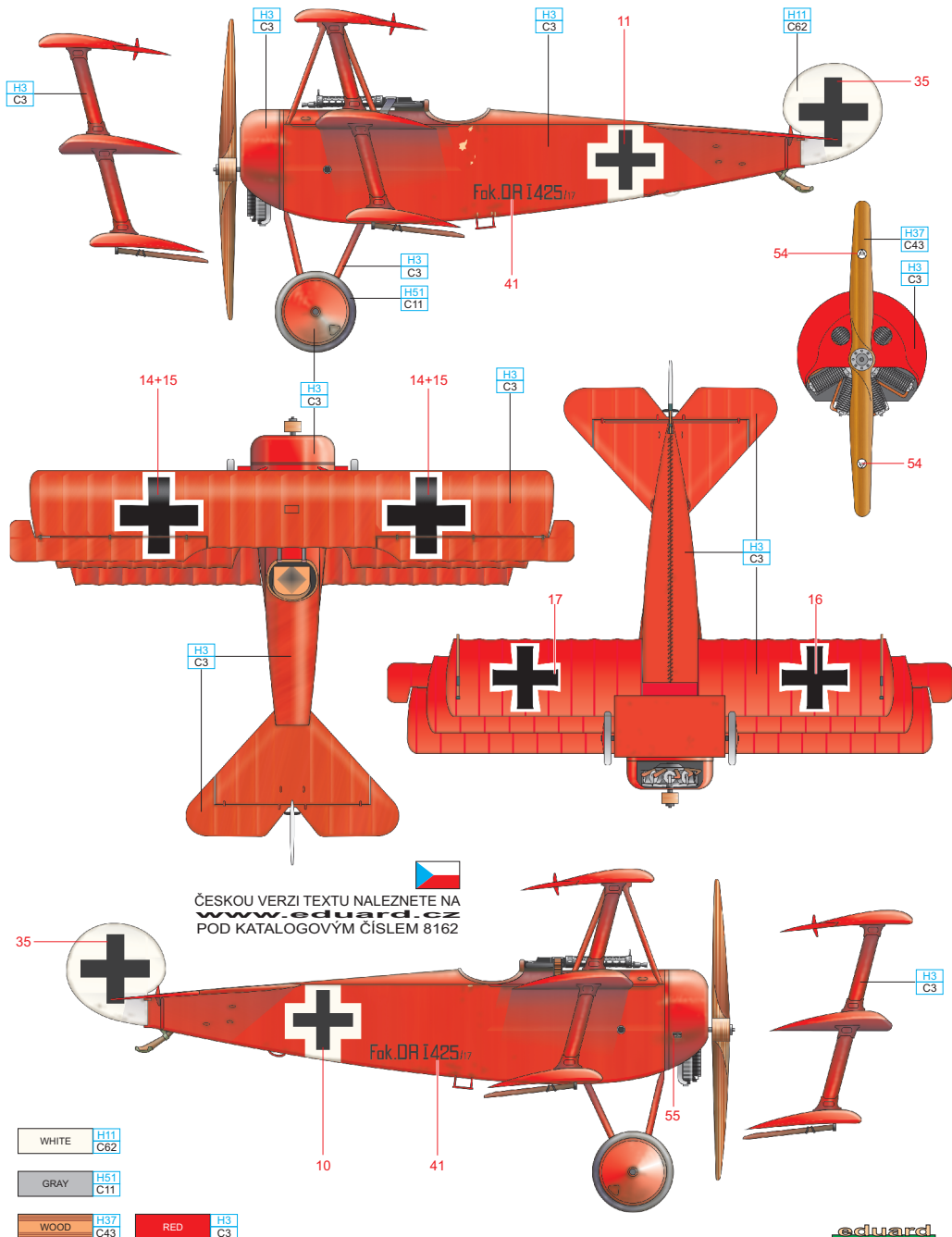

# B 577/17 flown by Lt. R. Klimke, Jasta 27, Halluin – Ost, France, May 1918

As a member of FFA 55, Rudolf Klimke got his first kill on the Russian Front in 1916. In May 1917, flying an Albatros C.VII with FA 19, he conducted a lone night attack on London along with his observer Leon. After being transferred to Kasta 13/KG 3, he served on Gotha bombers. A Sopwith fighter was shot down by the crew of Klimke, Leon and Reintrop over London on June 7th, 1917. After that, Klimke underwent training at Jastaschule I and in September 1917, he was assigned to Jasta 27, where he gradually increased his kill count to eventually reach seventeen on September 21st, 1918. On that day, however, he was seriously wounded by fire coming from an enemy fighter. He managed to land on his own field, but was nearly killed by a bombing of the hospital he was in. He would not return to a combat unit before the war ended.

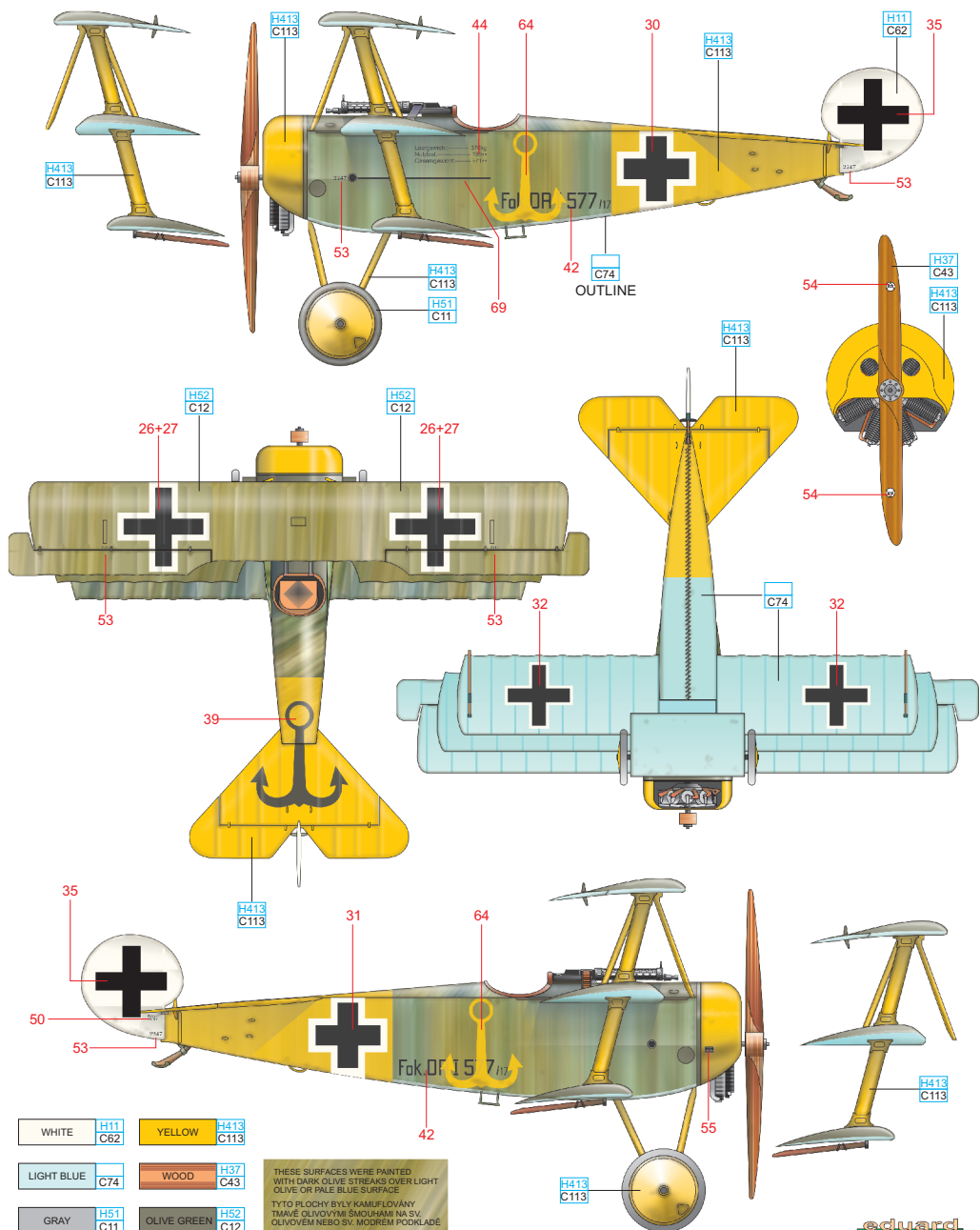



After command of Jasta 18 was handed over to August Raben, who previously CO'd Jasta 11, the appearance of the unit's fighters went through some changes. Originally, the noses of the fighters were in red, while the remaining upper and side surfaces were in dark blue. Now, the upper and side surfaces of the front of the aircraft were in red while the rear section including tail were in white. The lower surfaces remained in the factory blue. The sides of the fuselage were painted with a black or white bird which symbolized the CO's name, since the translation of Rabe is 'Raven'. The original white base colour in the crosses on the upper wing were irregularly overpainted with red after the changes to the national markings were implemented in the spring of 1918.

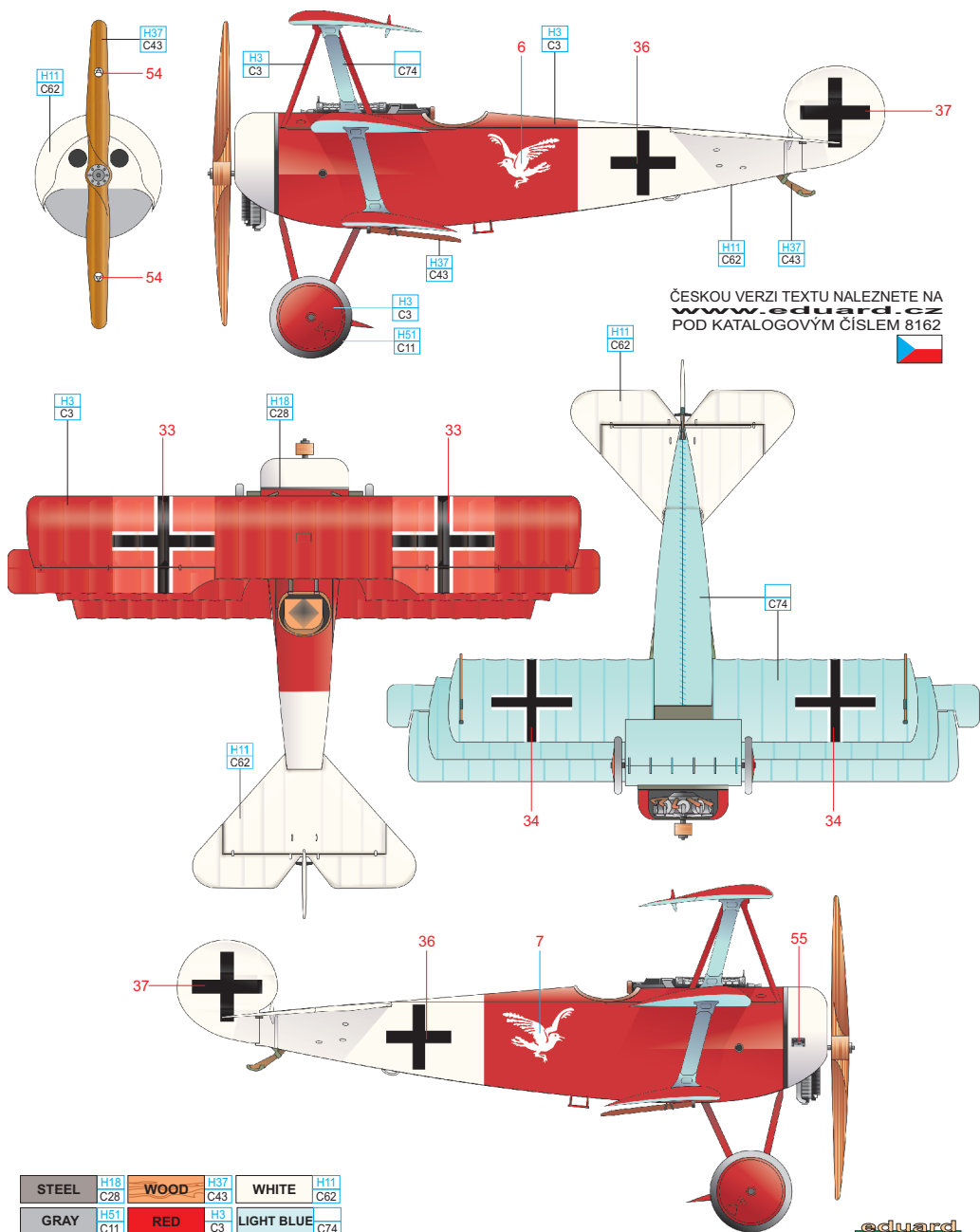

STEEL	H18 C28	WOOD	H37 C43	WHITE	H11 C62
GRAY	H51 C11	RED	H3 C3	LIGHT BLUE	C74

# D 213/17 flown by Lt. Friedrich Kempf, Jasta 2, 1917

Friedrich Kempf was born on May 9th, 1894 in Freiburg. He entered military service in 1913, interrupting his technical studies. In May 1915, he transferred from the infantry to the air force. He flew with Kagohl 4, a bombing unit, on both the Western and Balkan Fronts. In April 1917, he was assigned to Jasta Boelcke with which he served his entire career as a fighter pilot, but twice interrupted by stints with Jastaschule I. Fritz Kempf distinguished himself more with his two Fokker Dr.Is than with his four kills (BE2e, Pup and two Camels). His planes were similar in appearance, and carried the taunting inscription 'Kempf Kennscht mi noch?' - 'Kempf Remember Me?'. Friedrich Kempf survived both world wars and died in 1966.

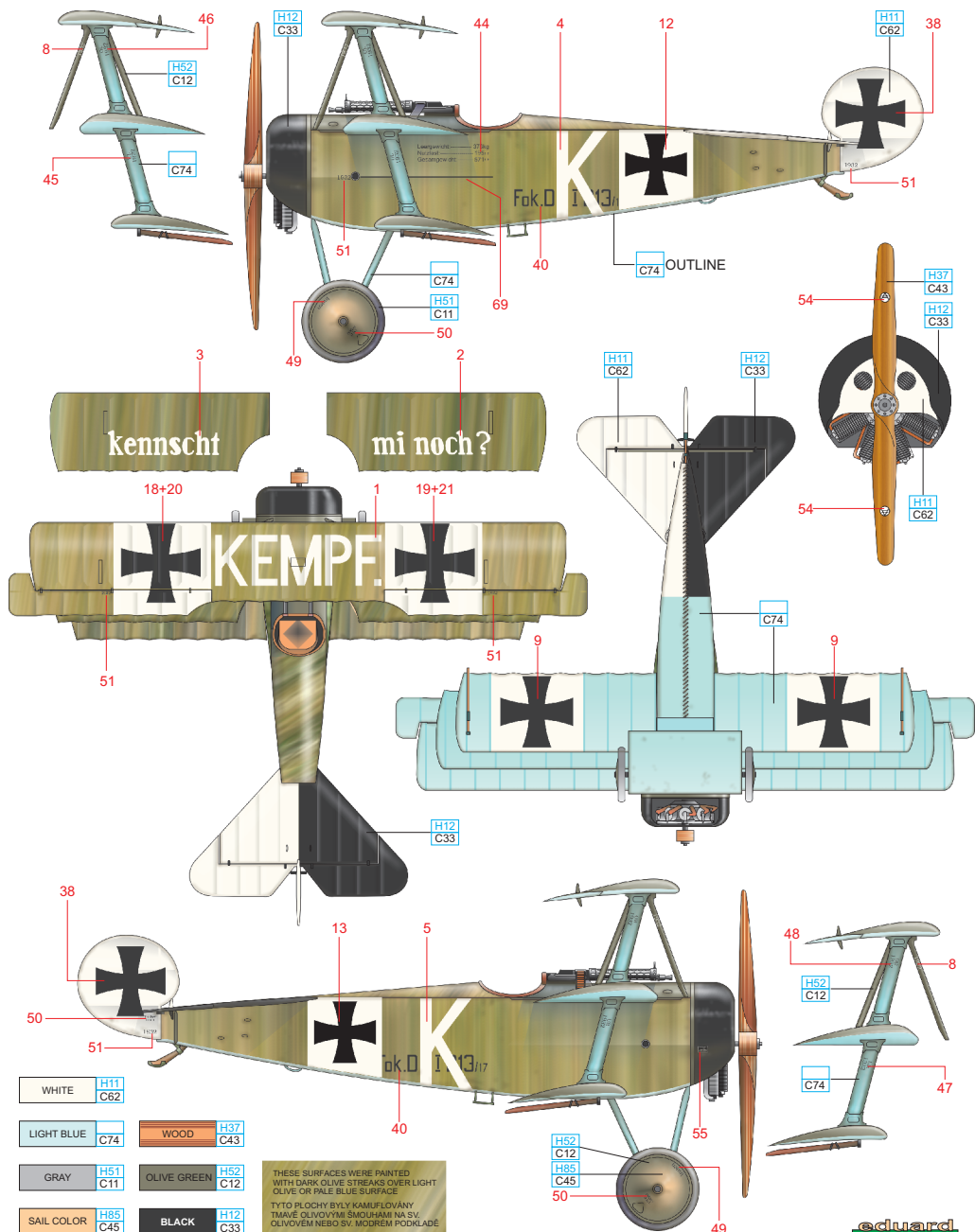

# E 425/17 flown by Rittmeister M. Freiherr von Richthofen, CO of JG 1, Lechelle, France, March 1918

Manfred Albrecht von Richthofen is rightfully considered the greatest fighter pilot of the First World War, during the course of which he downed eighty enemy aircraft. He was assigned to the air force on his own request in 1915, prior to which he served with a cavalry unit. After a meeting with Oswald Boelcke, he requested pilot training and on completion of that, he was assigned to combat units. After another meeting with his role model and mentor, he joined the ranks of the newly formed Jasta 2, led by O. Boelcke himself. In January 1917, he was awarded the highly coveted Pour le Merite and was subsequently made CO of Jasta 11. In June 1917, he received orders to form Jagdgeschwader 1, which was formed out of components of Jastas 4, 6, 10 and 11, and he would serve in this role until his death on April 21st, 1918. Von Richthofen had his aircraft painted red from January 1917 when he CO'd Jasta 11 and flew an Albatros D.III. He carried this practice over to the Fokker Dr.I which he flew as Jagdgeschwader 1 CO.

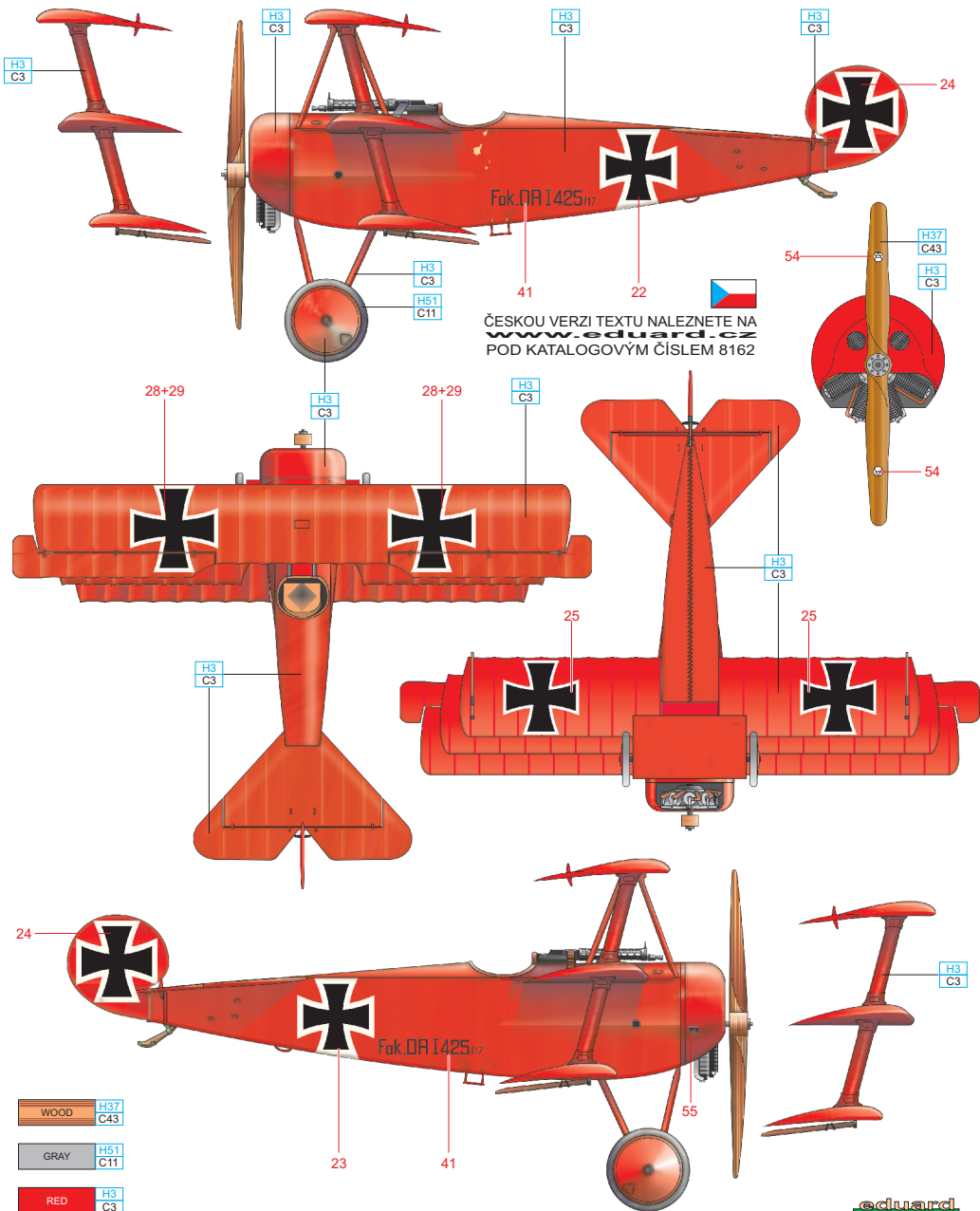

# F flown by Lt. W. Steinhäuser, Jasta 11, Avesnes-le-Sec, France, February 1918

Werner Steinhäuser was born on June 29th, 1893. As a pilot during the war, he first served with FA 261 where he would achieve his first kill. In December 1917 he was reassigned to Jasta 11. He gradually increased his count to ten victories. In the morning of June 26th, 1918, he was shot down in his Fokker D.VII and killed in combat with French SPADs from either Spa 124 or Spa 93. The serial number of this aircraft has not been positively identified, with some sources claiming 564/17. It does appear, though, that Steinhäuser flew at least two Dreidecker aircraft similar in appearance. The exact arrangement of the bands on the rear of the aircraft is not photographically confirmed. This section of the aircraft could also have been red with yellow bands.

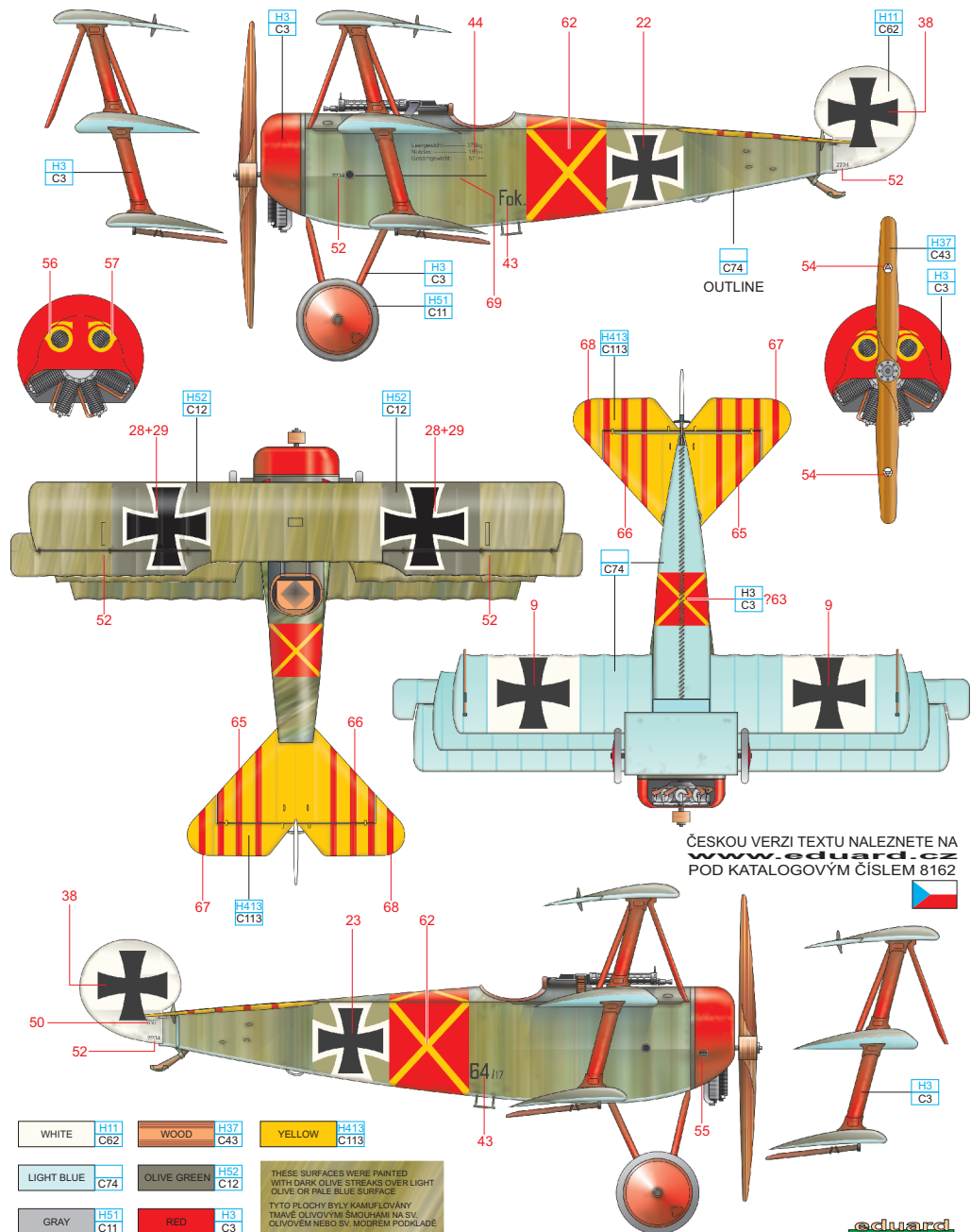

ČESKOU VERZI TEXTU NALEZNETE NA  
[www.eduard.cz](http://www.eduard.cz)  
 POD KATALOGOVÝM ČÍSLEM 8162



WHITE	H11 C62	WOOD	H37 C43	YELLOW	H413 C113
-------	------------	------	------------	--------	--------------

LIGHT BLUE	C74	OLIVE GREEN	H52 C12
------------	-----	-------------	------------

GRAY	H51 C11	RED	H3 C3
------	------------	-----	----------

THESE SURFACES WERE PAINTED WITH DARK OLIVE STREAKS OVER LIGHT OLIVE OR PALE BLUE SURFACE  
 TYTO PLOCHY BYLY KAMUFOVÁNY TRÁVĚ OLIVOVÝMI ŠTŘEHAMI NA SVĚTLĚ OLIVOVÉM NEBO SV. MODRÉM PODKLÁDE

**eduard**